



Russell Hobbs

INSTRUCTIONS AND WARRANTY



MODEL NO: 23972ZA

RUSSELL HOBBS PEARL GLIDE IRON

Congratulations on purchasing our Russell Hobbs Pearl Glide Iron. Each unit is manufactured to ensure safety and reliability. Before using this appliance for the first time, please read the instruction manual carefully and keep it for future reference.

FEATURES

1. Dry, steam and spray iron
2. 24000-2600W
3. *Pearl infused ceramic soleplate for a 50-percent smoother glide
4. *Two times more durable soleplate - designed to be hardwearing and long-lasting
5. 150g steam shot for the toughest wrinkles and 40g continuous steam for tackling creases
6. Anti-drip feature means water won't drip onto your clothes as you iron
7. Self-clean feature helps to prevent the build-up of limescale which can help lengthen the lifespan of your appliance
8. A generous 315ml water tank means you don't have to fill up so often
9. Self-clean anti-calc feature
10. 2m Power cord
11. Variable temperature control
12. Variable and vertical steam
13. Textured handle for comfort and grip
14. Power indicator light
15. For domestic use only
16. 2 year warranty (1 year retail • 1 year extended upon online registration of product • visit www.russellhobbs.co.za)

*Vs Russell Hobbs Standard Ceramic

IMPORTANT SAFEGUARDS

When using any electrical appliance, basic safety precautions should always be followed including the following:

1. Please read the instructions carefully before using any appliance.
2. Always ensure that the voltage on the rating label corresponds to the mains voltage in your home.
3. Incorrect operation and improper use can damage the appliance and cause injury to

the user.

4. The appliance is intended for household use only. Commercial use invalidates the warranty and the supplier cannot be held responsible for injury or damage caused when using the appliance for any other purpose than that intended.
5. This appliance is not intended for use by persons (including children) with reduced physical, sensory or mental capabilities, or lack of experience and knowledge, unless they have been given supervision or instruction concerning the use of the appliance by a person responsible for their safety.
6. Children should be supervised to ensure that they do not play with the appliance.
7. Check the power cord and plug regularly for any damage. If the cord or the plug is damaged, it must be replaced by the manufacturer or a qualified person in order to avoid an electrical hazard.
8. Do not use the appliance if it leaks, has been dropped or damaged in any way. In case of damage, take the unit in for examination and/or repair by an authorised service agent
9. To reduce the risk of electric shock, do not immerse or expose the motor/ electrical assembly, plug or the power cord to water or any other liquid.
10. Never immerse the unit in water or any other liquid for cleaning purposes.
11. Remove the plug from the socket by gripping the plug. Do not pull on the cord to disconnect the appliance from the mains. Always unplug the unit when not in use, before cleaning or when adding or removing parts.
12. The use of accessory attachments that are not recommended or supplied by the manufacturer may result in injuries, fire or electric shock.
13. A short cord is provided to reduce the hazards resulting from becoming entangled in or tripping over a longer cord.
14. Do not let the cord hang over the edge of a table or counter. Ensure that the cord is not in a position where it can be pulled on inadvertently.
15. Do not allow the cord to touch hot surfaces and do not place on or near flammable goods, near an open flame, hot gas or electric burner or a heated oven.
16. Use of an extension cord with this appliance is not recommended. However, if it is necessary to use an extension lead, ensure that the lead is suited to the power consumption of the appliance to avoid overheating of the extension cord, appliance or plug point. Do not place the extension cord in a position where it can be pulled on by children or animals or tripped over.
17. This appliance is not suitable for outdoor use. Do not use this appliance for anything other than its intended use.
18. Do not carry the appliance by the power cord.

19. Always operate the appliance on a smooth, even, stable surface. Do not place the unit on a hot surface.
20. Ensure that the switch is in the "0" or "OFF" position after each use.
21. Don't iron clothing while it's being worn – you'll burn or scald the wearer.
22. Don't touch the soleplate and keep away from the steam emitting from it.
23. Take care when emptying the iron – it may contain hot water.
24. Don't use the iron in the vicinity of children.
25. Use the iron on a stable, level, heat-resistant surface, preferably an ironing board.
26. Don't leave the iron unattended while plugged in, or while it's standing on the ironing board. It could be knocked over by you, by a child or by a pet.
27. Don't fill the iron directly from the tap, use the water beaker provided.
28. Don't fill past the MAX level mark shown on the water tank or water will leak from the iron during use.
29. Deposits or minerals in the water supply will generate scale and block the steam holes in the soleplate. It is advisable to use distilled water when filling your iron. Do not use chemically distilled water.
30. Leave the iron upright to cool down fully before cleaning and storing away.
31. Don't use the iron for any purpose other than those described in these instructions.
32. Take care not to scratch the soleplate – avoid buttons, zips, etc.
33. When placing the iron on its heel rest, ensure that the surface on which it has been placed is clean and stable.
34. The iron has a protective thermal fuse, which will blow if it overheats. If this happens, the iron will stop working and must be returned for repair.
35. Always unwind and straighten the power cord before use.
36. Unplug the iron from the mains electrical supply before:
 - a. Cleaning
 - b. Filling with water or emptying the water tank
 - c. Immediately after use
 - d. When not in use
 - e. When moving
37. The appliance generates high temperature steam. Always handle with care and warn other users of potential danger.
38. Don't let the power cord touch the soleplate as it may result in damage as well as a potential fire hazard.
39. Empty the water tank after each use.
40. Do not add perfume, vinegar or other chemical liquids into the water tank as they may result in damage to the appliance.

41. Do not operate this appliance by means of an external timer.
42. The manufacturer does not accept responsibility for any damage or injury caused by improper or incorrect use, or for repairs carried out by unauthorised personnel.
43. In case of technical problems, switch off the appliance and do not attempt to repair it yourself. Return the appliance to an authorised service facility for examination, adjustment or repair. Always insist on the use of original spare parts. Failure to comply with the above-mentioned precautions and instructions, could affect the safe operation of this appliance.

PARTS DIAGRAM

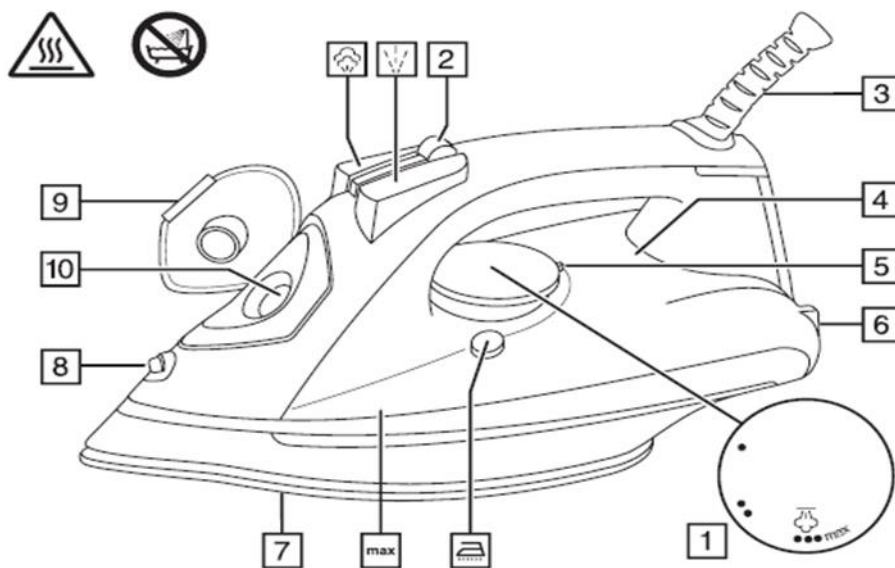

1. Temperature control
2. Steam control
3. Swivel cord
4. Light
5. Marker
6. Heel
7. Soleplate
8. Spray nozzle
9. Water inlet cover
10. Water inlet

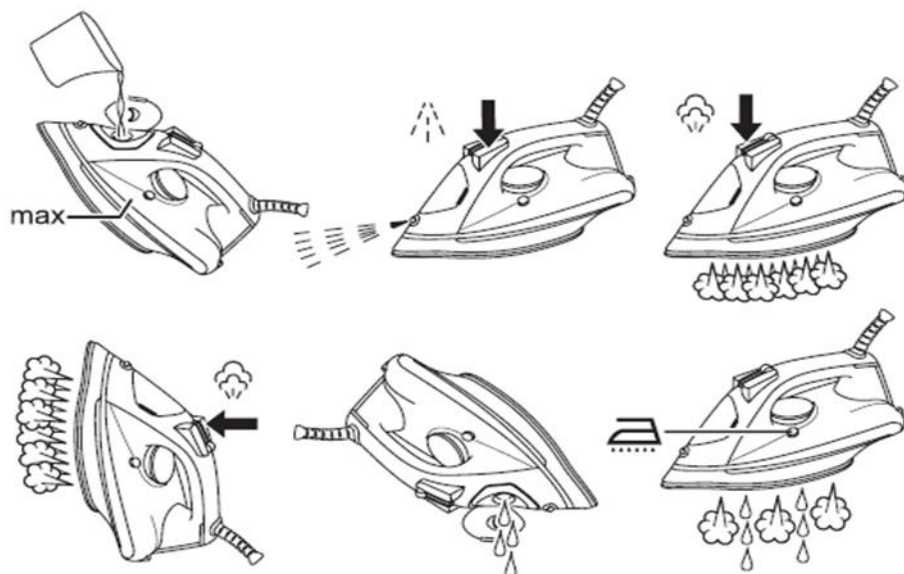

OPERATING INSTRUCTIONS

BEFORE FIRST USE

- Remove any protective films or stickers from the soleplate and the iron's body.
- Wipe the soleplate with a dry soft cloth.
- Unwind and straighten the power cord.
- Fill the iron as described in the section "How to Fill the Water Tank".
- Connect the appliance to a suitable mains power supply outlet.
- Turn the Temperature Dial to the MAX position.
- Wait until the pilot light cycles a few times or wait for at least 3 minutes for the temperature to stabilize before ironing. Once the pilot light goes off after the cycle, then the required temperature is reached.
- Move the steam knob to the ON position - steam will start to come out from the vents on the soleplate.
- Begin first time ironing with an old towel.
- When the water tank is empty and there is no more steam that can be produced; the preparation work is completed.
- The iron is now ready for normal use.

Note: It is normal for small amount of smoke to be produced the first time you use the iron, this will quickly disappear. When using the steam function for the first time, do not direct the steam towards the laundry, as there could be debris from the steam vents.





HINTS AND TIPS FOR IRONING

1. Sort the articles to be ironed according to the type of fabric. This will minimize the frequency of temperature adjustment for different garments.
2. Start ironing the fabrics requiring the lowest temperature and progress to the higher ones because the iron heats up quicker than it cools down.
3. “Test iron” a small area on the backside or inside of the garment if you are unsure about the type of fabric. Start with a low temperature and increase gradually.
4. Wait for about three (3) minutes before ironing when changing the temperature. The iron needs time to cycle to the temperature selected.
5. Delicate fabrics such as silk, wool, velour, etc. are best ironed with an ironing cloth to prevent shine marks.
6. You may need to press the steam button a few times to activate the burst of steam function.
7. Always keep the soleplate smooth – avoid contact with sharp, hard, metal objects.

TEMPERATURE SETTING GUIDE

1 Check for textile care  symbols

TEMPERATURE SETTING GUIDE

Label marking	Dot setting
 cool – nylon, acrylics, polyester	•
 warm – wool, polyester mixtures	••
 hot – cotton, linen	•••
Max – denim	max
 do not iron	-

If the instructions on the fabric label differ from this guide, follow the instructions on the label.

HOW TO FILL THE WATER TANK

1. Disconnect the appliance from main power supply outlet.
2. Ensure that the temperature dial and steam knob are in the “MIN” and “OFF” positions.
3. Open the water inlet cover.
4. Place the iron on its heel rest and tilt forward approximately at a 45-degree angle.

5. Fill water through the water-filling inlet hole up to the MAX level mark indicated on the side of the iron/ water tank. Never fill above this mark. Pour the water slowly to prevent an airlock and over filling.
6. Close the water inlet cover and wipe off any spillages on Iron.

Note: For the best result, it is advisable to use de-mineralized water or distilled water. Do not use chemically de-scaled water or any other liquids

SWITCHING ON THE IRON

1. Set the temperature control to • and set the steam control to .
2. Stand the iron on its heel.
3. Put the plug into the power socket (switch the socket on, if it's switchable).
4. Turn the temperature control to align the setting you want next to the marker. The light will come on.
5. When the iron reaches the temperature you set, the light will go of. It'll then cycle on and off as the thermostat operates to maintain the temperature.

WATER SPRAY FUNCTION

This function can be used at any time and it does not affect other functions.

1. Water spotting affects some fabrics. Test this out on a hidden part of the fabric.
2. Lift the iron off the fabric.
3. Aim the spray nozzle at the fabric.
4. Press the  button - you may have to press it 2 or 3 times to pump water through the system.

NOTE: When using the water spray function, ensure that there is enough water in the water tank.

BURST OF STEAM

This function works well for tough wrinkles and heavy fabrics. By pressing the burst of steam button () a intense burst of steam is emitted from the soleplate. This can be very useful when removing stubborn creases. This function can be used once the iron has reached maximum temperature. For optimal results, there should be a five (5) second interval between presses of the burst of steam button.

To further prevent leaking water from the soleplate, do not press the burst of steam button continuously for more than three (3) seconds. Allow at least a one (1) minute interval before pressing the burst of steam button again. Stubborn creases should be removed within three (3) burst of steam button presses.

VERTICAL STEAMING

Burst of steam can also be applied when holding the iron in a vertical position. This function is useful for removing wrinkles on garments in hanging position, hanging curtains, or other hanging fabrics.

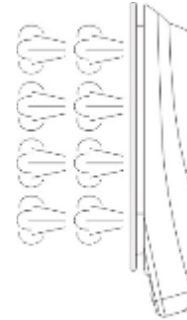

- Check that there's adequate ventilation behind the fabric, otherwise steam will build up, causing mildew.
- Check that there's nothing behind the fabric that may be damaged by the steam. Check that pockets, turn-ups, and cuffs are empty.
- Check that there's water in the reservoir.
- Set the temperature control to max and set the steam control
- Hold the iron close to (but not touching) the fabric.
- Press the steam burst button.
- Leave 4 seconds between shots, to let the temperature build up.

Note: It may be necessary to press the burst of steam button few times to start this function. During the use of 'Burst of Steam', stop ironing when the pilot light turns on and then start ironing again only after the pilot light has turned off.

Warning: Do not apply steam on any clothes or fabrics that are being worn by human or pets. The temperature of the steam is very high and will burn or scald.

DRY IRONING

This function irons without the use of steam.

If you're going to be dry ironing for 20 minutes or more, empty the reservoir first to avoid spontaneous bursts of steam.

1. Connect the iron with a suitable mains power supply outlet.
2. Set the steam knob to position "0"/ "no steam"/ "OFF".

3. Turn the temperature dial to the correct ironing temperature according to the recommendation of the garment label.
4. Wait until the pilot light cycles a few times or wait for at least 3 minutes for the temperature to stabilize before ironing.
5. Once the pilot light goes off after the cycle, then the required temperature is reached.
6. After use, turn the temperature dial to the “**0**”/ “**OFF**”/ “**MIN**” position to switch it off.
7. Disconnect the iron from mains power supply outlet.
8. Follow cleaning and maintenance instructions.

STEAM IRONING

This function can only be used at a higher ironing temperature – moderate or max position.

1. Connect the iron to a suitable mains power supply outlet.
2. Set the steam knob to position “**0**”/ “**no steam**”.
3. Turn the temperature dial to the correct ironing temperature according to the recommendation of the garment label.
4. Wait until the pilot light cycles a few times or wait for at least 3 minutes for the temperature to stabilize before ironing. The pilot light will glow to indicate that the iron is heating up.
5. When the required temperature is reached, the pilot light will go off. The iron is ready to use.
6. After use, turn the temperature dial to the **MIN** position to switch off the iron.
7. Disconnect the iron from mains power supply outlet.
8. Follow cleaning and maintenance instructions.

Note: This iron has an anti-drip feature: if you are ironing garments for a long period of time, the soleplate temperature may decrease. The anti-drip function will ensure that water does not leak from the soleplate during this time.

SELF-CLEANING

This function removes the scale and minerals built up in the steam chamber. The iron will remain in the best condition if this function is performed once every two weeks. You may choose to use the function more frequently depending on the hardness of the water used or water available in your local area.

- Make sure that the appliance is unplugged from the mains supply outlet.

- Set the steam knob to the “0”/ “no steam” / “OFF” position.
- Fill the iron as described in “How to Fill the Water Tank” and fill the water tank up to the **MAX** position. Do not put vinegar or other descaling agents in the water tank.
- Place the iron on a stable surface in an upright standing position on its heel.
- Connect the iron to mains supply outlet.
- Turn the temperature dial to the **MAX** position.
- Wait until the pilot light cycles a few times or wait for at least 3 minutes for the temperature to stabilize before ironing.
- After a few cycles when the required temperature is reached, the pilot light will go off.
- Thereafter, turn the temperature dial to the “0”/ “OFF”/ “MIN” position.
- Disconnect the iron from mains power supply outlet.
- Hold the iron horizontally over a sink.
- Hold/ press the self-cleaning button in and gently shake the iron to and fro.
- Steam and boiling hot water will emit from the holes on the soleplate which contains impurities, scale, minerals and flakes (if any) that deposited in the steam chamber that were deposited from previous use.
- Release the self-cleaning button as soon as all the water in the tank has been used up.
- Repeat the self-cleaning process if the iron still contains a lot of impurities.
- After the self-cleaning process, put the plug into the wall socket, set the temperature dial to the **MAX** position and let the iron heat up to allow the soleplate to dry.
- Turn the temperature dial to the “0”/ “OFF”/ “MIN” position and unplug the iron when it has reached the set ironing temperature.
- Move the hot iron over a piece of used cloth to remove any water stains that may have formed on the soleplate.
- Let the iron cool down before you follow storage instructions.

Caution: Keep skin/body away from the hot water.

ANTI-SCALE/ CALCIUM FEATURE

An anti-scale agent has been incorporated as an advanced feature in the design of this iron. It is an extra measure to help prevent limescale/ calcium build-up and prolong the life of your iron.

*** Products returned under warranty with faults due to scale will be subject to a repair charge.**

CLEANING AND MAINTENANCE

- After use, lift the iron with the water inlet filling hole downwards to empty the remaining water from the water tank into the sink.
- Insert the plug into the socket and set the temperature to MAX for 1-2 minutes to evaporate the remaining water. Once done, turn the dial to “0”/ “OFF”/ “MIN”, unplug the iron and let it cool down before storing it.
- This appliance is for household use only and is not serviceable.
- Do not open or change any parts by yourself. Please refer to a qualified electrical service department or return to the supplier if servicing is necessary.
- Always remember to unplug the unit from the electrical outlet when not in use and before cleaning. Ensure that the temperature dial is set to “0”/ “OFF”/ “MIN”.
- Ensure that the steam knob is set to the “0”/ “no steam”/ “OFF” position.
- Wipe the soleplate with a damp cloth and a non-abrasive (liquid) cleaner. Once done, buff the soleplate with a clean dry cloth.
- If fibre has adhered/ stuck to the soleplate, use a damp cloth with vinegar to wipe the fibre from the soleplate.
- If scale has blocked a steam hole, please remove it gently using a toothpick. Be careful not to damage the surface of the soleplate
- The body of the appliance should be cleaned with a damp cloth. Do not let water enter the appliance and cause damage to any electrical components.
- Do not use bleach or other abrasive substance or solvents to clean your appliance as it can be damaging to the finish.
- Do not immerse the appliance in water or any other liquid or hold it under a running tap to clean.

Note: Never use sharp or rough objects to remove deposits from the soleplate. Never use any abrasive or descaling agents to clean the iron.

STORING THE APPLIANCE

- Complete Cleaning and Maintenance as instructed above.
- Ensure that the steam knob is set to the “0”/ “no steam”/ “OFF” position.
- Ensure that all parts are dry before storing.
- Store only once the iron has cooled completely.
- Store the appliance vertically in its box or in a clean, dry place.
- Never store the appliance while it is still wet or dirty.

- Never wrap the power cord around the appliance.

TROUBLE-SHOOTING

Problem	Possible Reasons	Solution
Not enough heat or too much heat	The temperature dial may have been rotated improperly. The temperature dial may have been set to the incorrect position or the iron is unplugged.	Set the temperature dial to the correct position and check if the iron is plugged into the mains power supply.
No steam is being produced or leakage.	The temperature dial has been set to “0”/ “OFF”/ “MIN” .	Set the temperature dial to the required position.
No burst of steam or no vertical steam.	The (vertical) burst of steam function has been used too often within a very short period. The iron is not hot enough.	Continue ironing in a horizontal position and wait a few minutes before using the (vertical) burst of steam function again.
Leaking water from soleplate.	Set the temperature dial so that it is not within the steam range.	Set the temperature dial as per steam range.
	There is still not enough heat being produced.	Use the steam button only after the indicator light has turned off.
	The water is over the max position.	Pour out the remaining water.
Little Steam	Check if the steam knob is in the correct position.	Set the steam knob to the correct position.
	A steam hole is blocked.	Clean the steam hole with distilled water.
	Too little water in the water tank.	Fill water into the tank as per earlier instructions.
Not Spraying	There is not enough pressure or air inside.	Press the spray nozzle by hand and push the spray button several times continuously.

SERVICING THE APPLIANCE

There are no user serviceable parts in this appliance. If the unit is not operating correctly, please check the following:

- You have followed the instructions correctly
- That the unit has been wired correctly and that the wall socket is switched on.
- That the mains power supply is ON.
- That the plug is firmly in the mains socket.

If the appliance still does not work after checking the above:

- Consult the retailer for possible repair or replacement. If the retailer fails to resolve the problem and you need to return the appliance, make sure that:

- The unit is packed carefully back into its original packaging.
- Proof of purchase is attached.
- A reason is provided for why it is being returned.

If the supply cord is damaged, it must be replaced by the manufacturer or an authorised service agent, in order to avoid any hazard. If service becomes necessary within the warranty period, the appliance should be returned to an approved Home of Living Brands (Pty) Limited service centre. Servicing outside the warranty period is still available, but will, however, be chargeable.

CHANGING THE PLUG

Should the need arise to change the fitted plug, follow the instructions below.

This unit is designed to operate on the stated current only. Connecting to other power sources may damage the appliance.

WARNING: If your appliance has three wires (Green/Yellow, Blue, Brown) then it **MUST** be earthed. Connect a three pin plug as shown below

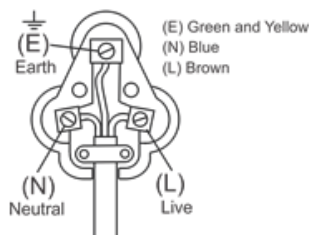

If your appliance has only two wires (Blue, Brown) then it does not need to be earthed. Connect a three pin plug as shown below

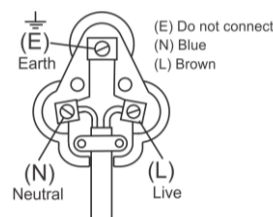

* Products returned under warranty with faults due to scale will be subject to a repair charge.

**PLEASE AFFIX YOUR PROOF OF PURCHASE/RECEIPT HERE
IN THE EVENT OF A CLAIM UNDER WARRANTY THIS RECEIPT MUST BE PRODUCED.**

2 YEAR WARRANTY

*1 year retail | 1 year extended
warranty upon registration*
visit www.russellhobbs.co.za*

W A R R A N T Y AND EXTENDED WARRANTY

1. Home of Living Brands (Pty) Limited ("Home of Living Brands") warrants to the original purchaser of this product ("the customer") that this product will be free of defects in quality and workmanship which under normal personal, family or household use and purpose may manifest within a period of 1 (one) year from the date of purchase ("warranty period").
2. Home of Living Brands shall extend the warranty period for a further period of 1(one) year ("extended warranty period"), on condition that the purchaser registers the product on the website, within 12 months from the date of purchase of the product. The website address for registration is as follows: <http://russellhobbs.co.za/info-pages/warranty-info.aspx>. The extended warranty period only applies to products purchased on or after 1 October 2017.
3. Where the customer has purchased a product and it breaks, is defective or does not work properly for the intended purpose, the customer must notify the supplier from whom the customer bought the product ("the supplier") thereof within the warranty period or if applicable, the extended warranty period. Any claim in terms of this warranty must be supported by a proof of purchase. If proof of purchase is not available, then repair, and/or service charges may be payable by the customer to the supplier.
4. The faulty product must be taken to the supplier's service centre to exercise the warranty.
5. The supplier will refund, repair or exchange the product in terms of this warranty subject to legislative requirements. This warranty shall be valid only where (a) the customer is not the cause of the product breaking, and (b) the product has been used for the intended purpose stipulated in the product manual. The warranty does not include and will not be construed to cover products damaged as a result of disaster, misuse, tamper, abuse or any unauthorised modification or repair of the product.
6. This warranty will extend only to the product provided at the date of the purchase and not to any expendables attached or installed by the customer. In this regard any accessories supplied with the product by the supplier, may be excluded in this warranty or extended warranty (see Exclusions to Warranty and Extended Warranty document).
7. If the customer requests that the supplier repairs the product and the product breaks or fails to work properly within 3 (three) months of the repair and not as a result of misuse, tampering or modification by or on behalf of the customer, then the supplier may replace the product or pay a refund to the customer, subject to the supplier's discretion.
8. The customer may be responsible for certain costs where products returned are not in the original packaging, or if the packaging is damaged. This will be deducted from any refund paid to the customer.

HOME OF LIVING BRANDS (PTY) LTD (JOHANNESBURG)

JOHANNESBURG
CAPE TOWN
DURBAN

TEL NO. (011) 490-9600
TEL NO. (021) 552-5161
TEL NO. (031) 303-1163

www.homeoflivingbrands.com
www.russellhobbs.co.za

www.facebook.com/RussellHobbsSA

EXCLUSIONS TO WARRANTY AND EXTENDED WARRANTY

1. Any accessories supplied with the product, including but not limited to, bowls, jugs, mills or carafes made either of glass or plastic and supplied with this appliance (hereinafter referred to as "the accessory or accessories"), is warranted to be free from material and workmanship defects for the duration of the appliance warranty.
2. The accessories should give trouble free service when used in accordance with the directions described in the instruction manual. However, the accessories will be damaged if subjected to impact, and this damage is not covered by the warranty. Such impact damage can occur either from the outside (if for example it is dropped or knocked against a hard surface), or from within (if for example foreign objects are placed within the accessories and the power is switched on).
3. Should you need to replace an accessory during the warranty period; a claim for a free replacement will only be considered if the item (including all shards and broken parts) is returned to the nearest HOLB service centre for examination.
4. The remains of the accessory will be carefully examined by the relevant professionals and if it is determined (at the sole discretion of HOLB) that the damage was caused by impact, then the claim will be refused and will not be covered by the warranty or any extended warranty.
5. Any replacement part provided in terms of clause 4 above will become a chargeable item payable by the customer.